

Innovation for Fukushima-Daiichi Decommissioning

Future Challenges and Expectations

Toyoaki Yamauchi, President of IRID

International Research Institute for Nuclear Decommissioning (IRID)

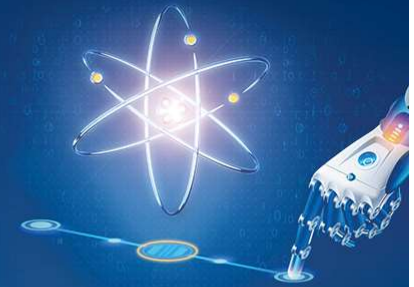

2023

Roles of Organizations in Decommissioning of Fukushima Daiichi

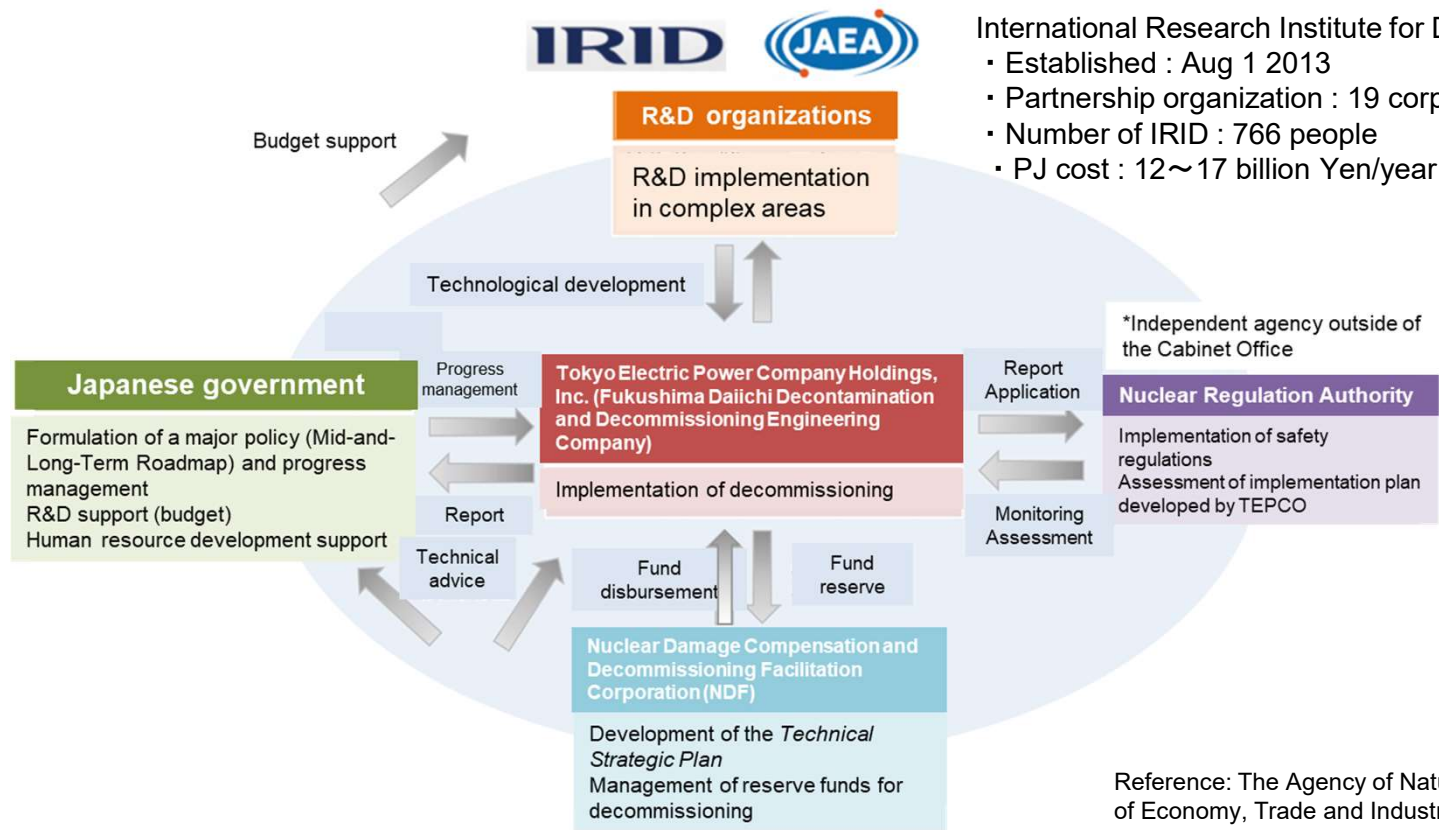

International Research Institute for Decommissioning(IRID)

- Established : Aug 1 2013
- Partnership organization : 19 corporations
- Number of IRID : 766 people
- PJ cost : 12~17 billion Yen/year

Reference: The Agency of Natural Resources Energy, Ministry of Economy, Trade and Industry of Japan website

Muon transmission measurement to identify fuel debris

- Muons are secondary cosmic rays, which generate when radiation from space collides with the atmosphere of the Earth. The cosmic ray muons are high-energy particles and can pass through materials.
- Muon tomography can measure the number of muons that pass through the reactor building to image the density of materials such as X-ray. It can be used to image the distribution of fuel debris in the reactor pressure vessel (RPV). (Smaller number of muons will pass through high density regions so higher density regions show dark shadow).

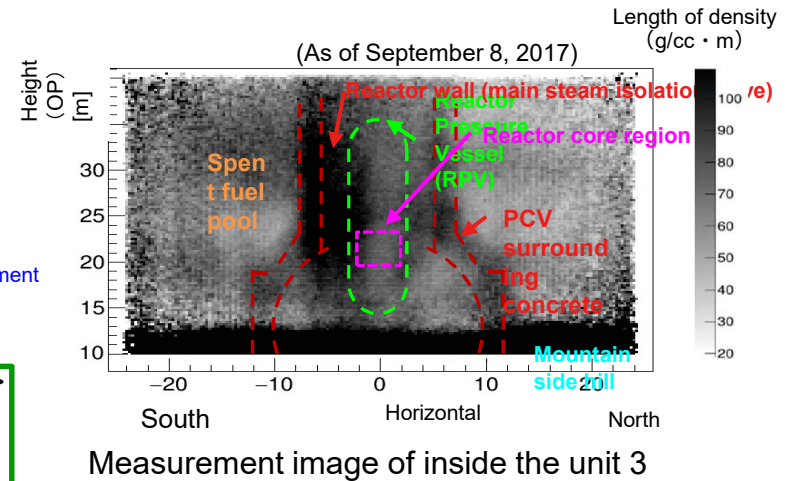
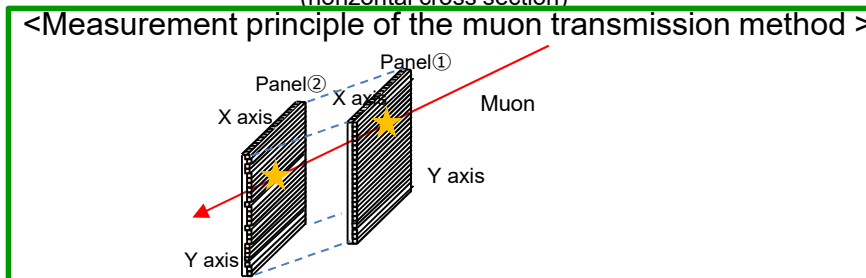
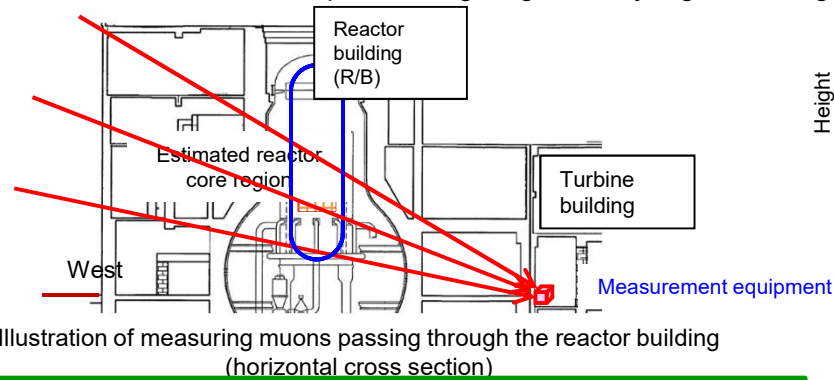

Reference: The TEOCO Holdings, Inc. website

Robots Developed for Investigation of PCV Interiors

Investigation of outside the pedestal (Unit 1)

- Shape-changing robot (B2 investigation)

Investigation of inside the pedestal (Unit 2)

- Crawler type remote-operated investigation robot (A2 investigation)

Investigation of inside the pedestal (Unit 3)

Investigation of inside the pedestal (Unit 1)

- Submersible robot

- Suspension type investigation equipment (A2' investigation)

Investigation results of inside the PCV (2017-2023)

- The investigation robot was developed based on a method of accessing the PCV. The robot investigated the inside of the Units 1-3 PCVs by using cameras.
- There are large differences in state of the damaged reactor cores depending on each Unit.
- The severity of damage is estimated in order of No. 1, No. 3 and No. 2.
- In Unit 2, part of fuel assembly (a handle) that has fallen on the floor outside of the reactor was observed.



Photo: Near the pedestal inner wall at the Unit 2 PCV bottom



Before touching deposits



Touching deposits

Photo: Touching pebble-like deposits by tool at the Unit 2 PCV bottom

Investigation results of the Unit 1 pedestal (2023)

- We confirmed the Unit 1 pedestal wall on inner and opening were damaged and remained only iron rebar.
- We assume that the lost concrete area of the pedestal inner wall (only rebar remains) is approximately 1 meter in height and 50cm in depth.
- The lost of the pedestal outer wall opening would be limited.

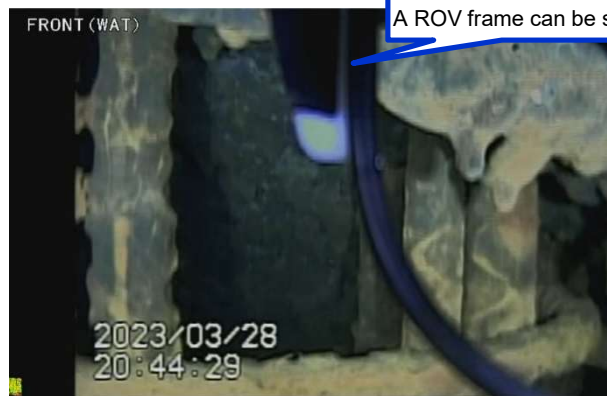
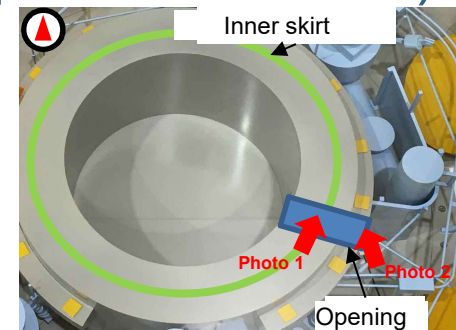

Photo 1: Concrete wall seen from the pedestal opening

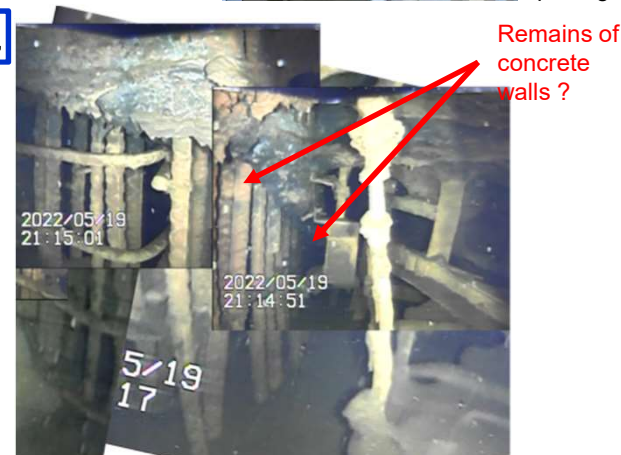

Photo 2: Concrete wall seen from the pedestal outside

©Tokyo Electric Power Company Holdings, Inc. All Rights Reserved.

Reference: Study committee of monitoring and evaluating specific nuclear facilities (the 107th), April 14, 2023

Photos processed by TEPCO Holdings, Inc.

Development and Demonstration of the Robot Arm

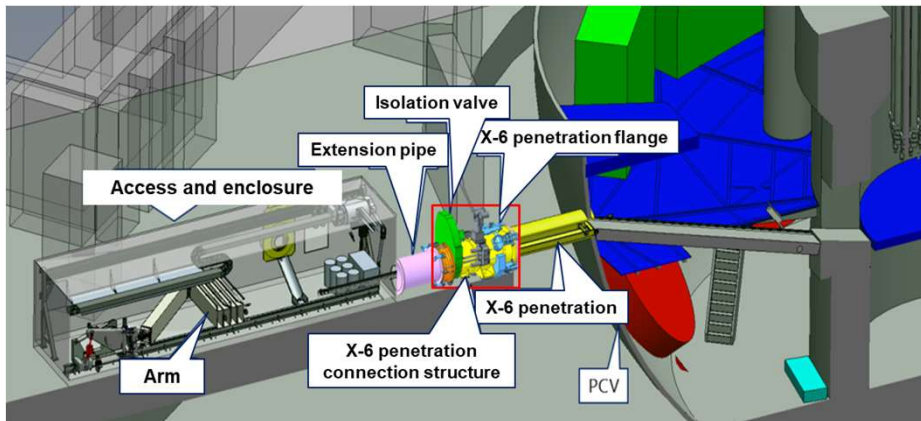

- A long cantilever arm with 22 meter in length and 4.6 ton in weight is designed to pass through a narrow X-6 penetration (55 cm in inner diameter and some deposits have accumulated inside the X-6 penetration).
- Fuel debris which is located on the pedestal floor 5 and 10 meters below the X-6 penetration end can be retrieved by using a tool operated with the program control system.
- Collected fuel debris will be stored in a container designed for Fuel debris, which is remotely operated in the enclosure.

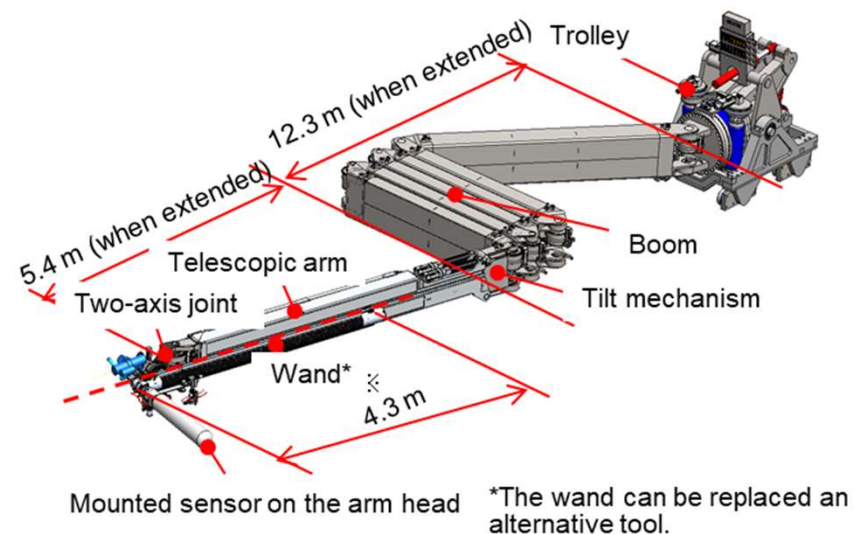

- The arm type access equipment was manufactured which can access on a wide range through the PCV penetration for maintenance of a control rod drive mechanism.
 - Total length of the arm: Approx. 22m
 - Investigation equipment up to 10kg can be loaded.

Preparation for Fuel Debris retrieval from Unit 2

Demonstration test at the JAEA Naraha Center for Remote Technology Development

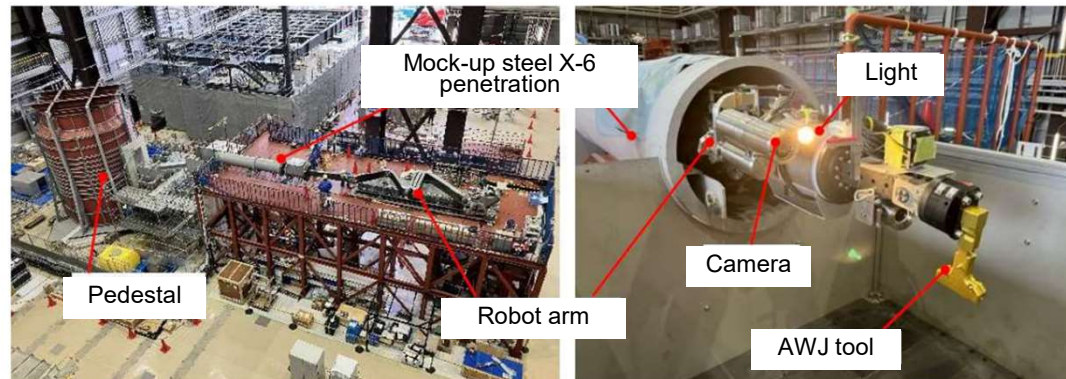

Reference: Report of the preparation status of investigation inside the Unit 2 PCV and trial retrieval of fuel debris issued by the Team Meeting and Countermeasures for Decommissioning and Contaminated Water Treatment Conference (the 115th).

Installation work of the connecting part at the Unit 2 site

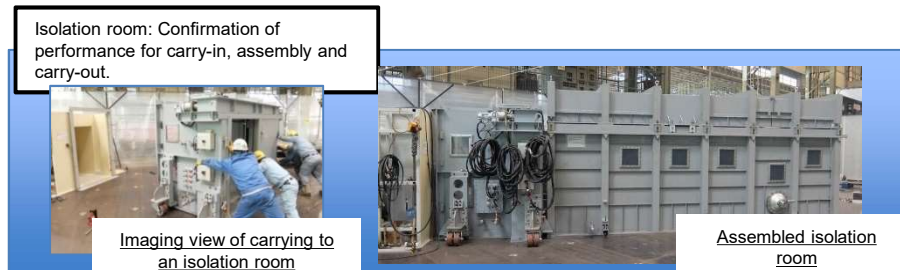

Summary of the Investigation Results (Unit 1)

- The Unit 1 reactor core was damaged about eight hours after the loss of power.
- Unit 1 has almost no fuel in the RPV, and deposits have spread outside the pedestal. The inner walls of the pedestal were also damaged.



Composite image of the Unit 1 entire pedestal floor
(Reference: the TEPCO Holdings website)



Shelf-shaped deposit
outside the Unit 1 pedestal
(Reference: TEPCO Holdings
website)

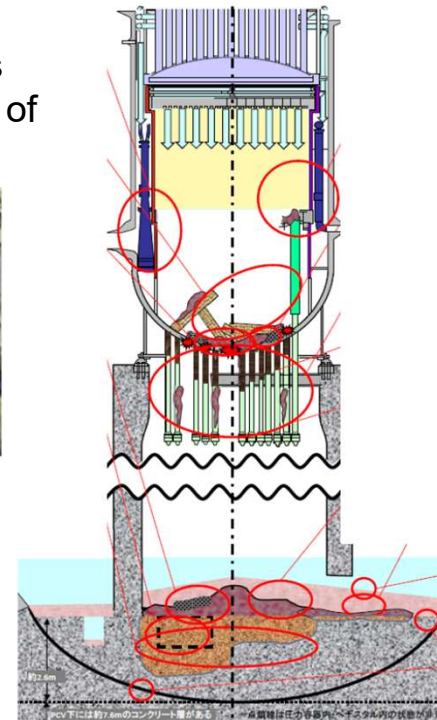

Damage estimation of the Unit 1 RPV/PCV
(From TEPCO website)

Summary of the Investigation Results (Unit 2)

- The Unit 2 reactor core was damaged about 3 days after the loss of power.
- Unit 2 has a lot of fuel left in the reactor pressure vessel (RPV). Although there is 1 meter-deposit on the pedestal floor. The RPV substructure retains its original form.

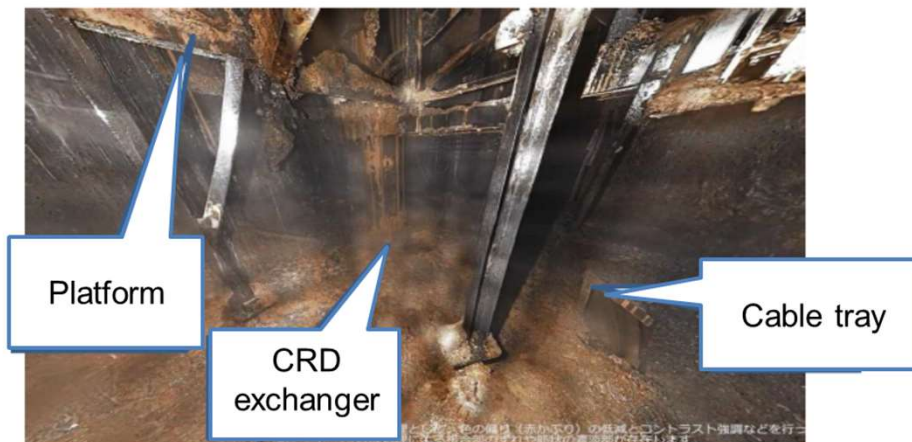

Wide angle photo of the Unit 2 entire pedestal floor
(Reference: the TEPCO Holdings website)

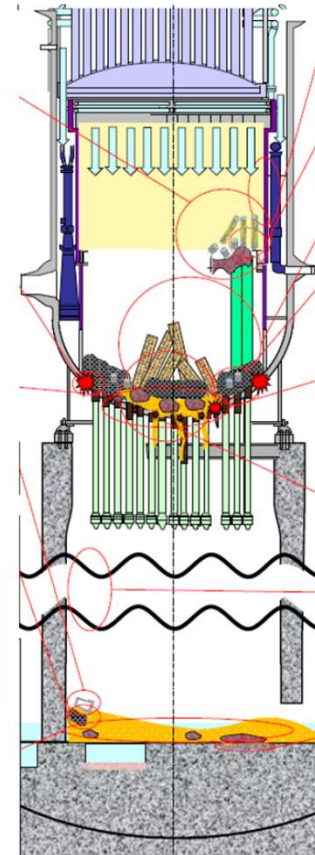

Summary of the Investigation Results (Unit 3)

- The Unit 3 reactor core was damaged about one and half day after the loss of power.
- Unit 3 have some fuel left in the RPV. There is 2-3 meters of deposits on the pedestal floor.



Photos taken from investigation inside the Unit 3 pedestal
(Reference: the TEPCO Holdings website)

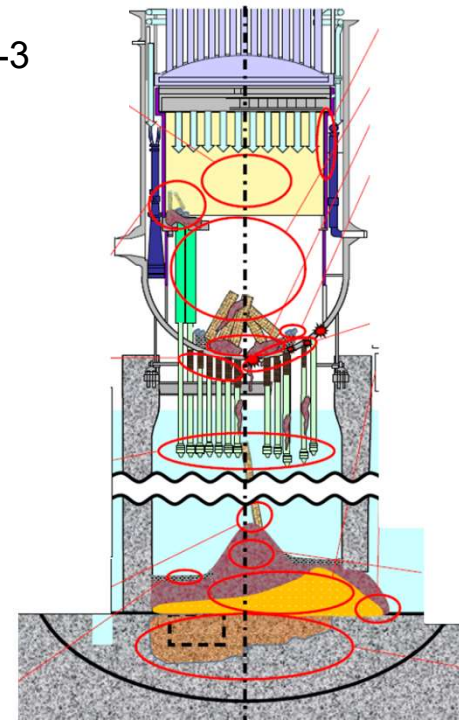

Damage estimation of the Unit 3 RPV/PCV
(From TEPCO HP)

Future Challenges and Expectations

- IRID has been conducting research and development for the investigation of inside the PCVs. The results of R&D revealed that the situation of inside the PCVs was clarified by photography taken by camera.
- Further investigation and clarification of the accident occurrence are needed to develop the future plan and to proceed with engineering for the decommissioning.
- We will continue working together for the decommissioning of the Fukushima Daiichi by sharing knowledge and experience with relevant parties from Japan and overseas.
- Elucidation of the accident phenomenon will be useful not only for Fukushima decommissioning, but also for accident operation procedures for operating reactors and for designing safety measures for new reactors. We will continue sharing these useful information with the world to contribute the safety of the nuclear power plant.